

APPENDIX J—3000 AND 4000 PRODUCT FAMILIES WIRING SCHEMATIC

WTEC III SYSTEM WIRING SCHEMATIC

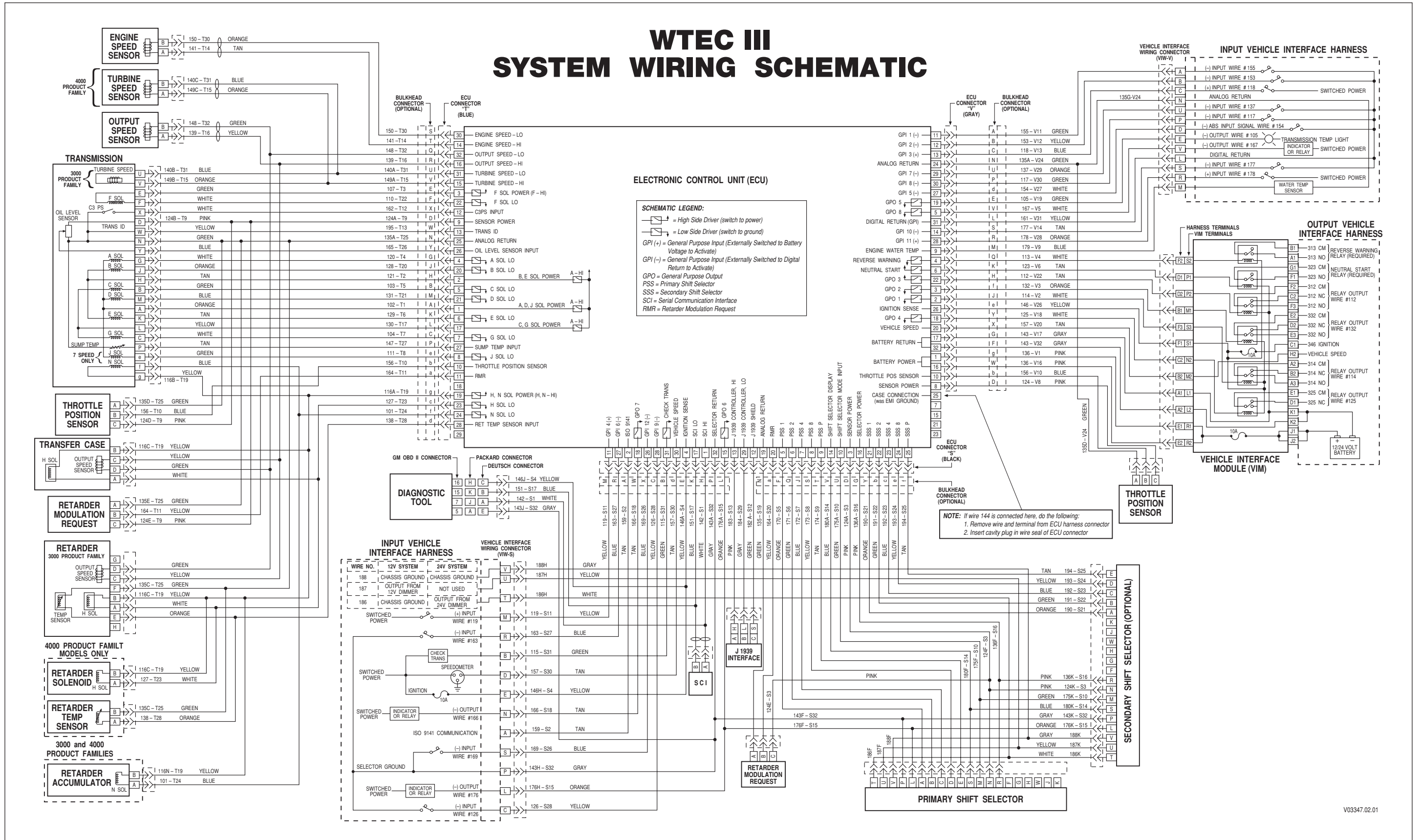

Figure J-1. 3000 and 4000 Product Families Wiring Schematic (TransID 1)

APPENDIX J—3000 AND 4000 PRODUCT FAMILIES WIRING SCHEMATIC

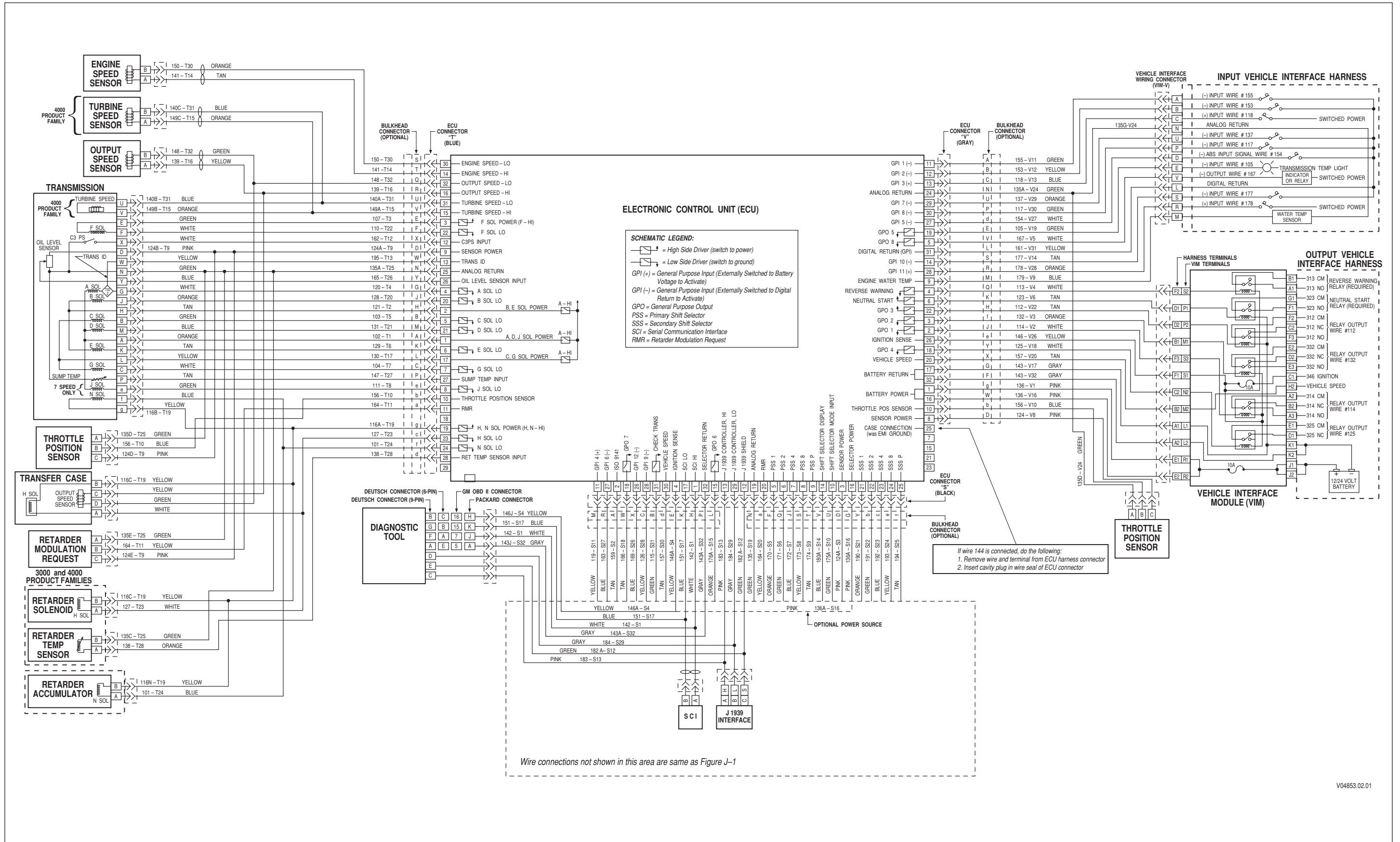
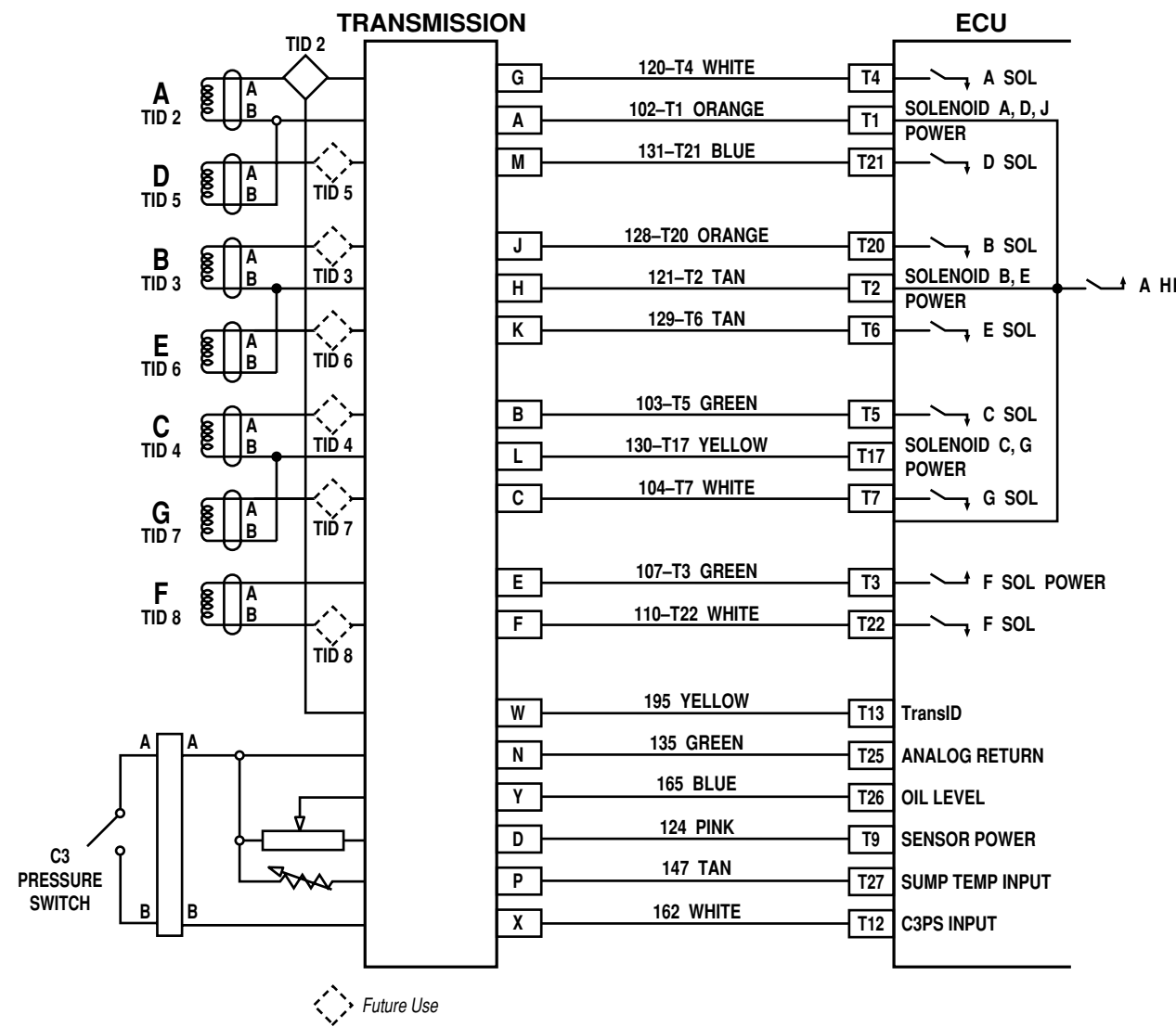

Figure J-2. 3000 and 4000 Product Families Wiring Schematic (TransID 2)

APPENDIX J—3000 AND 4000 PRODUCT FAMILIES WIRING SCHEMATIC



TRANSID — 2 AND FUTURE TID PROVISIONS
(Same as Figure J-1, except as shown)

V04855

TID-2 Started Production 1/5/1998
TID-3 Started Production 4/3/2000

Figure J-3. 3000 and 4000 Product Families Wiring Schematic (TransID Details)